

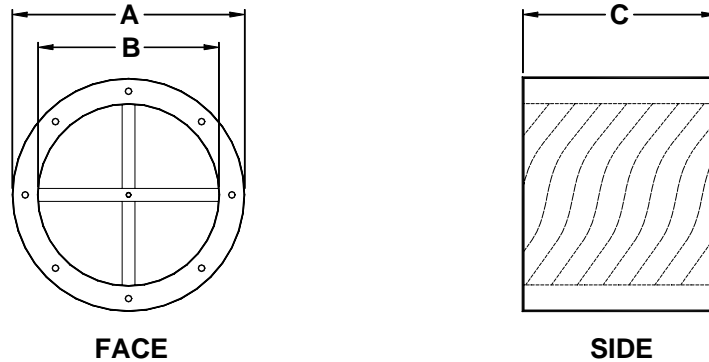

**3030 FGR-IL**

## Inline Spiral Silencer



Dimensions				
A = Dia. O.D.	B = Dia. I.D.	C = Length	Face Flow I.D.	Net Weight
36 in.	30 in.	30 in.	30 in.	120 lbs.

### DYNAMIC INSERTION LOSS

Octave Bands	1	2	3	4	5	6	7	8
Center Freq. Hz	63	125	250	500	1000	2000	4000	8000
Face Velocity	Dynamic Insertion Loss in Decibels							
-4000	20	22	22	26	32	46	50	53
-3000	19	22	22	25	31	46	50	53
-2000	19	21	21	25	31	45	49	52
-1000	19	20	21	25	31	45	49	52
+1000	19	20	21	25	31	45	49	52
+2000	19	20	20	25	31	44	48	51
+3000	18	20	20	25	31	44	48	51
+4000	18	20	20	25	30	45	48	51

### AERODYNAMIC PERFORMANCE DATA

Static Pressure Loss in Inches of H <sub>2</sub> O										
	.05	.10	.15	.20	.25	.30	.40	.50	.75	1.00
Airflow in CFM	2465	6380	7915	9150	10250	11220	12875	14500	17750	20510

Tel: (909) 796-6200



Fax: (909) 796-6223



**3030 FGR-IL**

**SELF GENERATED SOUND RATINGS**

Forward Flow								
Octave Bands	1	2	3	4	5	6	7	8
Center Freq. Hz	63	125	250	500	1000	2000	4000	8000
Face Velocity	Generated Sound in Sound Power Level (Lw) (dB re 10 <sup>-12</sup> Watts)							
1000	(52)	(41)	(31)	(22)	(18)	(19)	(22)	(25)
2000	(53)	(42)	(41)	40	40	41	(25)	(27)
3000	54	44	43	42	42	43	33	35

Reverse Flow								
Octave Bands	1	2	3	4	5	6	7	8
Center Freq. Hz	63	125	250	500	1000	2000	4000	8000
Face Velocity	Generated Sound in Sound Power Level (Lw) (dB re 10 <sup>-12</sup> Watts)							
1000	(52)	(41)	(31)	(22)	(18)	(19)	(22)	(25)
2000	(53)	(42)	(41)	39	40	40	(25)	(27)
3000	53	44	42	42	42	43	33	35

**NOTE:** Sound power levels in parentheses have reached ambient levels in the test facilities test room or are determined by instrument limitations. Actual levels are less than or equal to levels indicated.

The above insertion loss values and self generated sound levels are extrapolated from actual test data from an independent testing facility per ASTM E477 "Standard Methods of Testing Duct Liner Materials and Prefabricated Silencers for Acoustical and Airflow Performance". Test reports available upon request.