

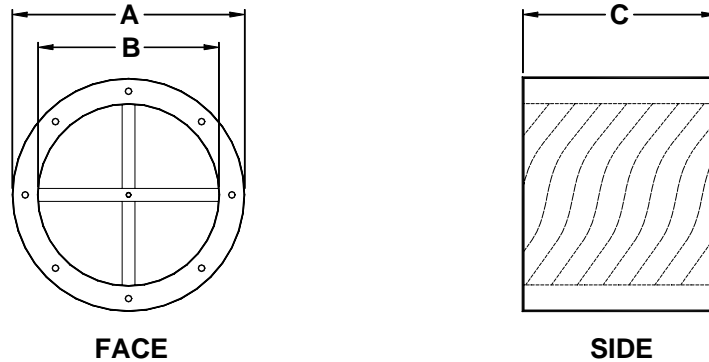

4848 FGR-IL

Inline Spiral Silencer



Dimensions				
A = Dia. O.D.	B = Dia. I.D.	C = Length	Face Flow I.D.	Net Weight
54 in.	48 in.	48 in.	48 in.	250 lbs.

DYNAMIC INSERTION LOSS

Octave Bands	1	2	3	4	5	6	7	8
Center Freq. Hz	63	125	250	500	1000	2000	4000	8000
Face Velocity	Dynamic Insertion Loss in Decibels							
-4000	17	20	16	25	34	45	50	54
-3000	17	20	16	25	33	44	50	53
-2000	16	20	15	24	33	44	48	53
-1000	16	20	15	24	33	44	48	53
+1000	16	19	15	24	33	44	48	53
+2000	16	19	15	24	32	44	48	52
+3000	16	19	15	24	32	43	48	52
+4000	16	19	15	23	32	43	47	52

AERODYNAMIC PERFORMANCE DATA

Static Pressure Loss in Inches of H ₂ O										
	.05	.10	.15	.20	.25	.30	.40	.50	.75	1.00
Airflow in CFM	5950	15400	19110	22085	24745	27090	31080	35000	42840	49525

Tel: (909) 796-6200



Fax: (909) 796-6223



4848 FGR-IL

SELF GENERATED SOUND RATINGS

Forward Flow								
Octave Bands	1	2	3	4	5	6	7	8
Center Freq. Hz	63	125	250	500	1000	2000	4000	8000
Face Velocity	Generated Sound in Sound Power Level (Lw) (dB re 10 ⁻¹² Watts)							
1000	(52)	(41)	(31)	(22)	(18)	(19)	(22)	(25)
2000	(53)	(42)	(41)	40	40	41	(25)	(27)
3000	54	44	43	42	42	43	33	35

Reverse Flow								
Octave Bands	1	2	3	4	5	6	7	8
Center Freq. Hz	63	125	250	500	1000	2000	4000	8000
Face Velocity	Generated Sound in Sound Power Level (Lw) (dB re 10 ⁻¹² Watts)							
1000	(52)	(41)	(31)	(22)	(18)	(19)	(22)	(25)
2000	(53)	(42)	(41)	39	40	40	(25)	(27)
3000	53	44	42	42	42	43	33	35

NOTE: Sound power levels in parentheses have reached ambient levels in the test facilities test room or are determined by instrument limitations. Actual levels are less than or equal to levels indicated.

The above insertion loss values and self generated sound levels are extrapolated from actual test data from an independent testing facility per ASTM E477 "Standard Methods of Testing Duct Liner Materials and Prefabricated Silencers for Acoustical and Airflow Performance". Test reports available upon request.