

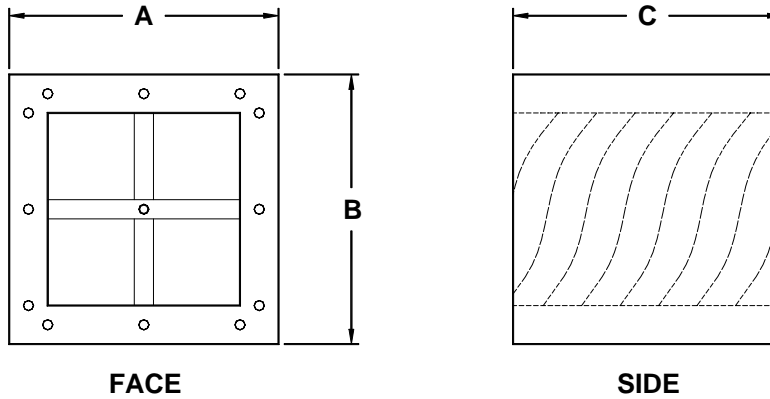

VA 88-1S-IL

Inline Spiral Silencer



Dimensions				
A = Width	B = Height	C = Length	Face Flow I.D.	Net Weight
12 in.	12 in.	12 in.	8 in. X 8 in.	18 lbs.

DYNAMIC INSERTION LOSS

Octave Bands	1	2	3	4	5	6	7	8
Center Freq. Hz	63	125	250	500	1000	2000	4000	8000
Face Velocity	Dynamic Insertion Loss in Decibels							
-4000	17	28	26	35	35	39	56	57
-3000	17	27	26	34	34	38	56	56
-2000	16	27	26	34	34	38	55	56
-1000	16	26	25	34	34	38	55	56
+1000	16	26	24	34	34	38	55	56
+2000	16	26	24	34	34	38	55	55
+3000	16	26	24	33	34	37	54	55
+4000	16	25	24	33	33	37	54	55

AERODYNAMIC PERFORMANCE DATA

Static Pressure Loss in Inches of H ₂ O										
	.05	.10	.15	.20	.25	.30	.40	.50	.75	1.00
Airflow in CFM	195	350	560	680	705	1070	1135	1300	1485	1560

Tel: (909) 796-6200



Fax: (909) 796-6223



VA 88-1S-IL

SELF GENERATED SOUND RATINGS

Forward Flow								
Octave Bands	1	2	3	4	5	6	7	8
Center Freq. Hz	63	125	250	500	1000	2000	4000	8000
Face Velocity	Generated Sound in Sound Power Level (Lw) (dB re 10 ⁻¹² Watts)							
1000	(53)	(40)	(30)	(22)	(18)	(19)	(24)	(28)
2000	(54)	(41)	41	42	42	41	(25)	(28)
3000	58	44	42	43	44	42	34	40

Reverse Flow								
Octave Bands	1	2	3	4	5	6	7	8
Center Freq. Hz	63	125	250	500	1000	2000	4000	8000
Face Velocity	Generated Sound in Sound Power Level (Lw) (dB re 10 ⁻¹² Watts)							
1000	(53)	(40)	(30)	(22)	(18)	(19)	(24)	(28)
2000	(54)	(41)	41	42	42	41	(25)	(28)
3000	58	44	42	43	44	42	34	40

NOTE: Sound power levels in parentheses have reached ambient levels in the test facilities test room or are determined by instrument limitations. Actual levels are less than or equal to levels indicated.

The above insertion loss values and self generated sound levels are extrapolated from actual test data from an independent testing facility per ASTM E477 "Standard Methods of Testing Duct Liner Materials and Prefabricated Silencers for Acoustical and Airflow Performance". Test reports available upon request.